

GRIDCOOLER[®]

KEEL COOLER

Installation and
Maintenance Manual
Form 180

Section	Title	
1.0	Planning & Location	<i>1</i>
1.1	Determining Proper Location – Typical	<i>1</i>
1.2	Determining Proper Location – Displacement Vessels	<i>1</i>
1.3	Determining Proper Location – Planing Vessels	<i>2</i>
1.4	Improper (Not Recommended) Locations	<i>2</i>
1.5	Mounting Considerations - Typical	<i>2-3</i>
1.6	Mounting Considerations – Displacement Vessels	<i>3</i>
1.7	Mounting Considerations – Planing Vessels	<i>3</i>
1.8	Bonding or Isolation	<i>3</i>
2.0	Installation	<i>4</i>
2.1	Making Holes	<i>4</i>
2.2	Fitting Up	<i>4</i>
2.3	Copper/Nickel Installation	<i>4-5</i>
2.4	Aluminum Installations	<i>5</i>
2.5	Plumbing	<i>5-6</i>
2.6	Filling & Testing	<i>6</i>
3.0	Special Installations	<i>7</i>
3.1	Cofferdam Installation with Compression Gaskets	<i>7</i>
3.2	Z OPTION™ Installations	<i>8</i>
3.3	L OPTION™ Support Plate Installation	<i>9</i>
3.4	Mounting Copper/Nickel Coolers on Aluminum Hulls	<i>10</i>
4.0	Forming the GRIDCOOLER® Keel Cooler	<i>11</i>
4.1	Bending a GRIDCOOLER Keel Cooler	<i>11</i>
4.2	Twisting a GRIDCOOLER Keel Cooler	<i>11</i>
5.0	Performance Issues	<i>12</i>
5.1	Wire Reinforced Rubber Hose	<i>12</i>
5.2	Piping	<i>12</i>

Section	Title	
5.3	Jacketwater	<i>12</i>
5.4	Thermostat	<i>12</i>
5.5	Jacketwater Pump	<i>12</i>
5.6	Air in the System	<i>12</i>
5.7	Foreign Matter	<i>12</i>
5.8	Expansion Tank	<i>12</i>
5.9	External Coating	<i>12</i>
5.10	Water Aeration	<i>12</i>
5.11	Moored at Dock	<i>12</i>
5.12	Placement	<i>12</i>
5.13	Mounting Gaskets	<i>12</i>
5.14	Glycol	<i>12</i>
5.15	Crushed Tubes	<i>12</i>
5.16	Blown Tubes	<i>12</i>
5.17	Marine Growth	<i>12</i>
5.18	Oil Deposits	<i>12</i>
5.19	Mineral Deposits	<i>12</i>
6.0	Maintenance	<i>13</i>
6.1	Exterior	<i>13</i>
6.2	Interior	<i>13</i>
6.3	Pressure Testing	<i>13</i>
7.0	Repair	<i>14</i>
7.1	Straightening	<i>14</i>
7.2	Copper/Nickel GRIDCOOLER Keel Cooler Repairs	<i>14</i>
7.3	Aluminum GRIDCOOLER Keel Cooler Repairs	<i>14</i>
7.4	Temporary Repair	<i>14</i>
7.5	Couplings Repair	<i>14</i>
8.0	Stray-Current Corrosion	<i>15</i>
9.0	Parts	<i>16-17</i>
10.0	Limited Warranty	<i>18-19</i>
11.0	Recommendation Form	<i>20</i>

1.0 PLANNING & LOCATION

To function properly, the FERNSTRUM® GRIDCOOLER® Keel Cooler must be properly located on your vessel's hull. Please consider the following before installing your keel cooler on most types of vessels. For additional details on displacement or planing hulls, refer to the appropriate sections.

1.1 DETERMINING PROPER LOCATION – TYPICAL

- 1.1.1 Sea water must flow over the entire length of the unit.
- 1.1.2 Always install the unit parallel, not transverse, to the skeg or keel. See Figures 1 & 2.

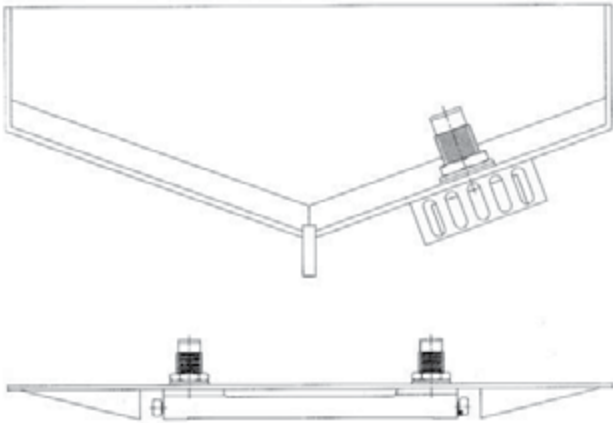

FIG. 1 External type installation with E1 OPTION end-mounted zinc anodes using fairing blocks for protection and streamlining.

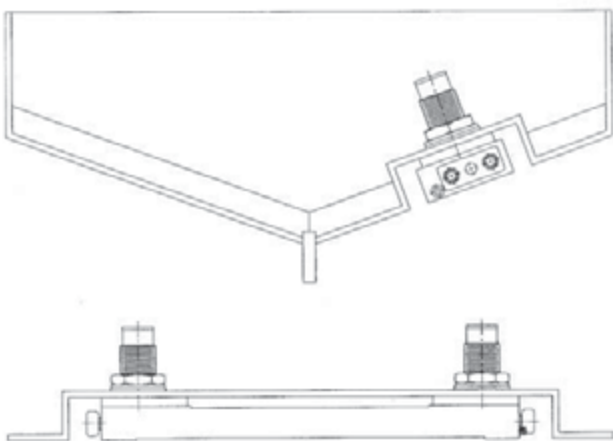

FIG. 2 Recess type installation with E1 OPTION end-mounted zinc anodes for reduced drag in high-speed craft.

- 1.1.3 When using a two-circuit cooling system, consisting of a high temperature jacketwater circuit and a low temperature aftercooler circuit, make certain the aftercooler circuit cooler is placed forward of the jacketwater circuit cooler. When room allows, they can be installed side by side with the aftercooler circuit lower on the hull (i.e. closer to the skeg or keel) and a divider plate between the high and low temperature units.
- 1.1.4 When the GRIDCOOLER unit is used on a generator set or if your application requires sizing for a hull speed of 0 knots, make sure that sea water can freely circulate past the cooler tubes. Do not recess a generator set unit on the bottom of a flat bottom boat unless the hull section where the unit will be mounted inclines a minimum of 20 degrees (from forward to aft) to avoid entrapping raw hot water around the tubes. See Figure 3.

1.2 DETERMINING PROPER LOCATION – DISPLACEMENT VESSELS

- 1.2.1 On vessels performing pushing, towing, dragging or pulling operations, install the unit as near to the propeller as possible (but not directly above it) to take advantage of its slip-stream during extreme towing operations. See Figure 3.

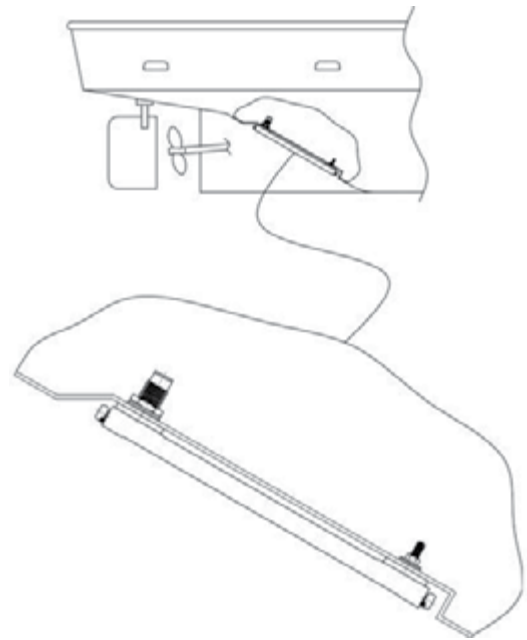

FIG. 3 Recessed installation is made by welding in a box-shaped recess in the underside of the hull. Note aft end of recess is tapered to prevent hot water entrapment.

- 1.2.2 When installing a unit on the side of a hull, position it well below the water line to avoid aerated surface water. Take the bow wave into consideration. Aeration reduces heat transfer and can cause overheating. See Figure 4.

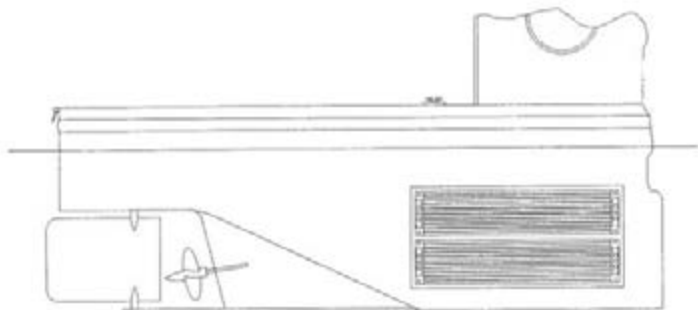

FIG. 4 *Side mounted coolers well below water line.*

1.3 DETERMINING PROPER LOCATION – PLANING VESSELS

1.3.1 For planing hull vessels, locate the unit as far aft as possible to avoid aeration.

1.4 IMPROPER (NOT RECOMMENDED) LOCATIONS

- 1.4.1 The area of the hull where the GRIDCOOLER® Keel Cooler is installed must not vibrate or flex severely.
- 1.4.2 To eliminate unnecessary stress and vibration on the cooler, do not locate the unit directly below engine mounts or above the propeller(s).
- 1.4.3 Make sure that hot water is not discharged on or near the unit.
- 1.4.4 Do not locate the unit on the front 1/3 of the hull for displacement hulls. Bowthruster coolers could be an exception, depending on the vessel.
- 1.4.5 The GRIDCOOLER Keel Cooler is designed to be mounted directly to the hull. Do not mount the unit to any external structure without first consulting the factory.

1.5 MOUNTING CONSIDERATIONS – TYPICAL

- 1.5.1 Some classed vessels (ABS or Coast Guard, for example) may require cofferdams, check with your local officials for more information. For this type of installation, see Cofferdam Installation in Section 3.1.
- 1.5.2 The GRIDCOOLER unit can be canted from the hull (sideways) to vertically align the nozzles. This can reduce interference problems with stringers on cofferdam installations. See Figure 5. (referred to section 3.1 for cofferdam installation)

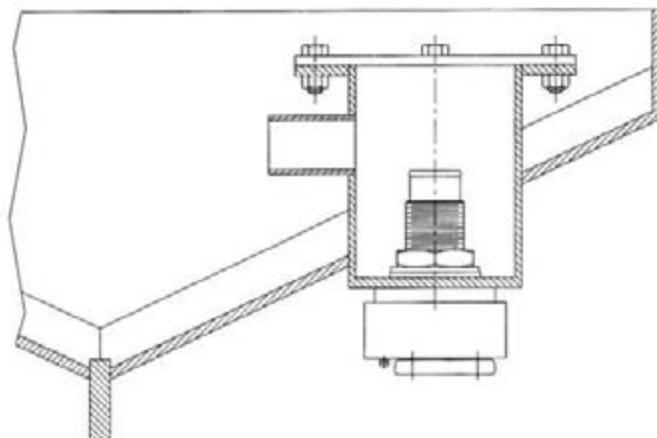

FIG. 5 *Canted Installation with Cofferdam.*

- 1.5.3 If the unit is recessed into the hull, make sure that it has a 1-1/2 in. (38 mm) minimum clearance on all sides (this does not include between the hull and the top of the cooler). The recess should be no deeper than 1/2 in. (13 mm) plus the hull projection (listed on installation drawing) of the cooler.
- 1.5.4 In extreme cases, where logs, debris, or dragging bottom may endanger the unit, a protective guard may be mounted over the unit. Make certain the grill guard does not cover more than 25% of the face opening. For examples of protective guards and different installations that have been used, see Figures 6 and 7.

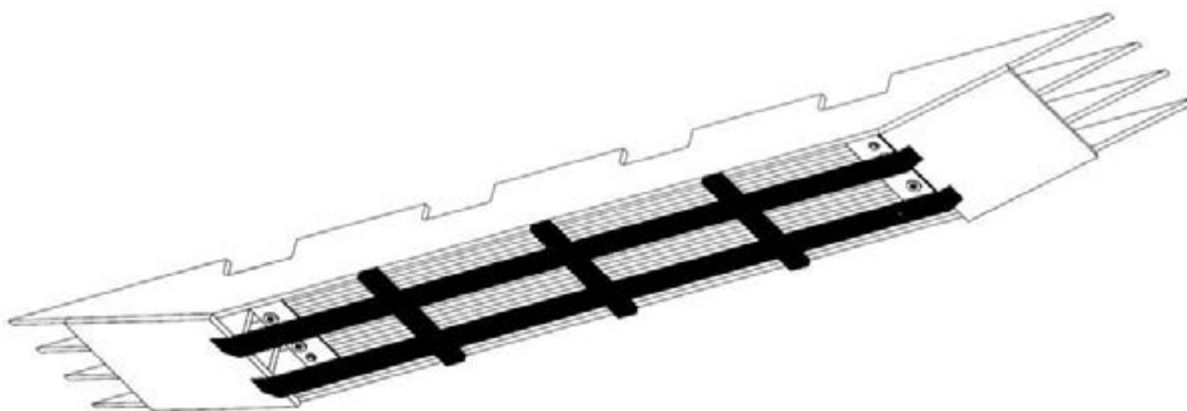

FIG. 6 *Example of external guarding*

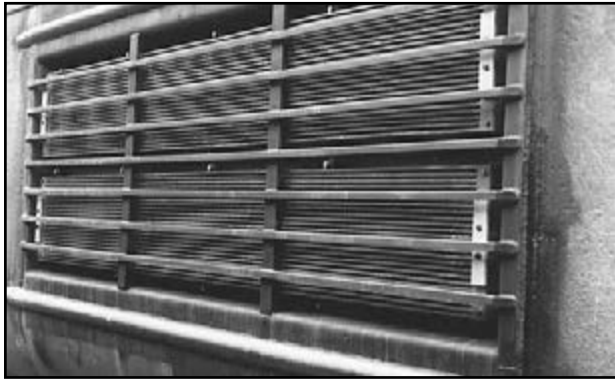

FIG. 7 Side mounted coolers

1.5.5 The unit can be bent to conform to the hull. The bending can be done at the yard or by R. W. Fernstrum & Company. Contact us if you are considering bending a unit. See Section 4.0 – Forming the GRIDCOOLER® Keel Cooler.

1.6 MOUNTING CONSIDERATIONS – DISPLACEMENT VESSELS

- 1.6.1 Owners of vessels with displacement hulls moving at less than 10 knots may find an external mounting with fairing blocks to their advantage; provided there isn't much chance of the unit being damaged in their operating environment.
- 1.6.2 When recessing the unit into the side of the hull for generator sets and/or equipment operating at dockside, angle the top of the recess box to allow convection current over the cooler. See Figure 8.

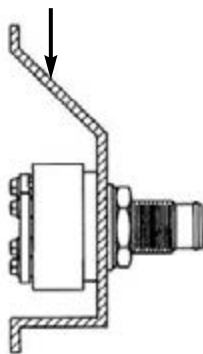

FIG. 8 Side Mounted Recess.

NOTE: Recess box with angled top suggested for generator set and equipment operating at dock side only. NOT required for propulsion engines.

1.6.3 When installing a multiple-pass unit on an incline, make sure that the nozzles are at the high end to avoid air entrapment. See Figure 9.

1.6.4 If coolers must be installed with the nozzles at the low end, special units can be ordered with additional vents in the stud end of the cooler.

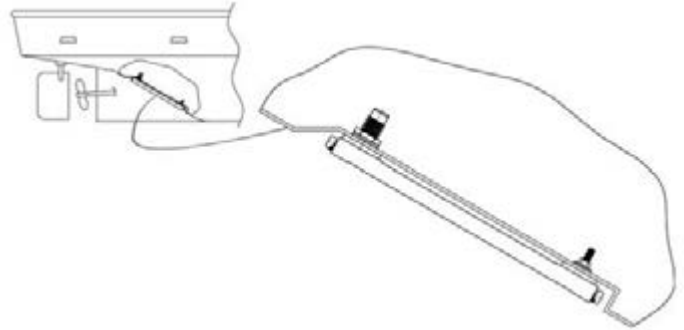

FIG. 9 U-Flow unit with E1 OPTION end mounted zinc anodes mounted on rake of vessel.

1.6.5 If side plates and fairing blocks are used, make sure that the side plates are scalloped (notched) out so they will not entrap water. Fairing blocks are most effective when installed with a 4 to 1 slope. See Figures 1 & 6.

1.7 MOUNTING CONSIDERATIONS – PLANING VESSELS

- 1.7.1 If you aren't sure as to whether or not you should recess the unit, we recommend using a recess on planing hulls and vessels moving at 10 or more knots.
- 1.7.2 High speed applications (10+ knots) can reduce the 1-1/2 in. clearance in section 1.3.4 to 1/2 in. minimum due to increased raw water flow over the cooler at high speed.
- 1.7.3 High speed applications and others that use E1 OPTION™ coolers should take into consideration the removal and replacement of zinc electrodes when sizing the length of a recess. See Figure 2.

1.8 BONDING OR ISOLATION TO MINIMIZE CORROSION

1.8.1 It is recommended that the installer consult with a corrosion engineer to review the corrosion protection system of the vessel to determine the best mode of installation for their particular situation. Typically it is common practice to isolate the heat exchanger from the hull. This ensures that the antifouling property of the copper nickel is at full potential. However, there are other variables that may effect the decision whether to isolate or bond the unit.

2.0 INSTALLATION

Once you have decided on the correct location, use the following steps as a guideline for installing your GRIDCOOLER® Keel Cooler:

2.1 MAKING HOLES

- 2.1.1 Measure the distance between the Inlet & Outlet nozzles from center to center (also measure to the centers of the support studs when applicable) before cutting holes for them in the ship's hull.
- 2.1.2 Make the holes through the hull 1/4 in. (6.4 mm) diameter oversized.
- 2.1.3 Make sure that the hull surfaces where the unit will be mounted are smooth and properly aligned (on steel hulls, if you burn the holes, grind the edges smooth afterwards). This will allow the gaskets to seal properly and insure that no undue stress will be placed on the cooler.

2.2 FITTING UP

- 2.2.1 Under normal conditions, the compression of the mounting gaskets puts sufficient tension on the nozzle nuts (and support bolt nuts when applicable) to prevent them from working loose. To seal out water, apply a polysulfide rubber sealant like BoatLIFE Caulk or 3M Marine Sealant 101 around the gaskets, washers, and the points where the nozzles and support bolts penetrate the hull before assembly. Remember to tighten the nuts a second time, after the caulking has set.

NOTE: BoatLIFE is available from Life Industries (www.boatlife.com), call 800-382-9706 for a dealer near you. Marine Sealant 101 is available from 3M (www.3m.com), call 888-364-3577 for a dealer near you.

2.3 COPPER/NICKEL INSTALLATION

- 2.3.1 Mounting gaskets supplied with the GRIDCOOLER Keel Cooler must be used to provide proper spacing between the unit and the ship's hull. See Figure 10.

NOTE: EXTERIOR GASKETS: All "BN" & "CN" Series Models have 1/2 in. (12.7 mm) gaskets as standard. All legacy "B" & "C" Series Models have 1/4 in. (6.4 mm) gaskets standard. The "D" Series Models have 3/4 in. (19 mm) gaskets standard, however, 1/4 in. gaskets are available upon request.

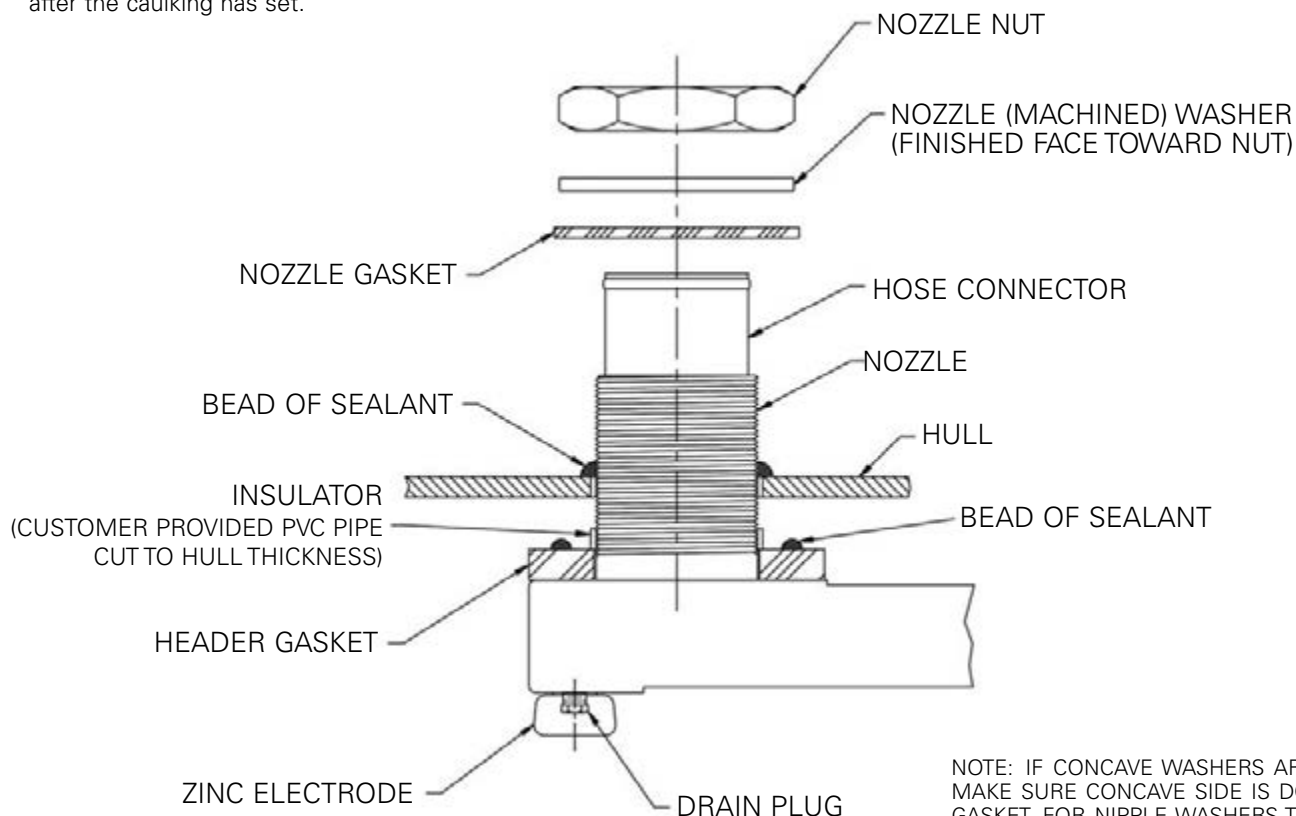

NOTE: IF CONCAVE WASHERS ARE USED, MAKE SURE CONCAVE SIDE IS DOWN ON GASKET. FOR NIPPLE WASHERS THAT ARE CAST, PLACE THE ROUGH SIDE AGAINST THE GASKET.

FIG. 10 Mounting Parts Placement

INSTALLATION

2.3.2 To avoid over-tightening any of the supporting nuts, we recommend the following torques for all standard installations:

COPPER/NICKEL UNIT NUT TORQUES FT.-LBS. (KG-M)			
NOZZLE THREAD SIZE			
.75" 19mm	1 - 1.5" 25 - 38mm	2" 51mm	2.5 - 3.5" 63 - 89mm
50 - 60 (7 - 8)	75 - 100 (10 - 14)	125 - 150 (17 - 21)	200 - 250 (28 - 35)
HEADER STUD		SUPPORT BOLT	
.625 - .75" 16 - 19mm	1" 25.4mm	.5 - .75" 13 - 19mm	
35 - 40 (5 - 5.5)	50 - 60 (7 - 8)	20 - 25 (3 - 3.5)	

2.3.3 Zinc electrodes are standard equipment with most copper/nickel units. They minimize the effects of galvanic corrosion, and should be replaced when deteriorated. The life of these plates varies with localities.

2.3.4 Attach the zinc electrodes using the special bolts and washers supplied with the unit. They can be found in a cardboard box inside the unit shipping box. See Figure 11.

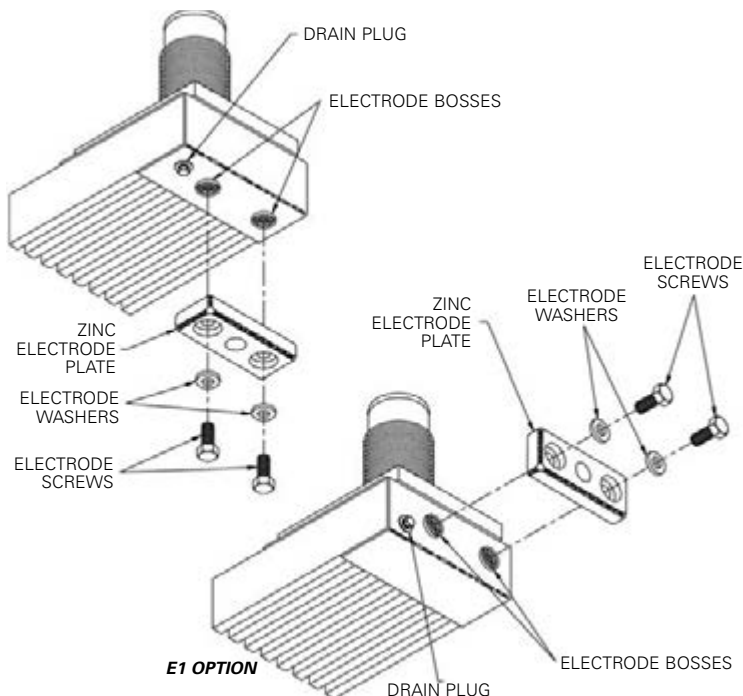

FIG. 11 Zinc Attachment Detail

NOTE: Zinc replacement kits, including zinc electrodes, screws, and washers, can be ordered from the factory. Just give us the model number of your GRIDCOOLER® Keel Cooler.

2.4 ALUMINUM INSTALLATIONS

2.4.1 An aluminum GRIDCOOLER Keel Cooler should be installed on **unpainted aluminum hulls only**.

2.4.2 The 1/4 inch mounting gaskets supplied with the unit must be used to provide proper spacing between the cooler and the ship's hull.

2.4.3 To avoid over-tightening any of the supporting nuts, we recommend the following torques for all normal installations.

ALUMINUM UNIT NUT TORQUES FT-LBS (KG-M)		
NOZZLE THREAD		SUPPORT BOLT
1" 25.4mm	1.5 - 3" 38 - 76mm	.625" 16mm
75 - 100 (10 - 14)	125 - 150 (17 - 21)	20 - 25 (3 - 3.5)

2.4.4 Most aluminum units have tapered threads on the nipples and no hose connectors (see installation drawing). These units can be piped directly to the engine, provided flexible couplings are used to remove engine vibration between the engine and the cooler.

2.4.5 If a wire reinforced rubber hose is used to connect the unit to the engine, put a screw-on coupling over the cooler nozzle threads.

2.4.6 Aluminum GRIDCOOLER Keel Coolers do not use zinc electrodes.

2.5 PLUMBING

NOTE: Prior to installing cooler, flush entire piping system to remove any debris.

2.5.1 Remove the orange nozzle plugs from the GRIDCOOLER unit before hooking up the plumbing to the cooler.

2.5.2 When converting an engine from inboard heat exchanger cooling to keel cooling, do not pipe the keel cooler to a heat exchanger, bypass the heat exchanger and pipe the keel cooler directly to the engine. See Figure 12 (next page).

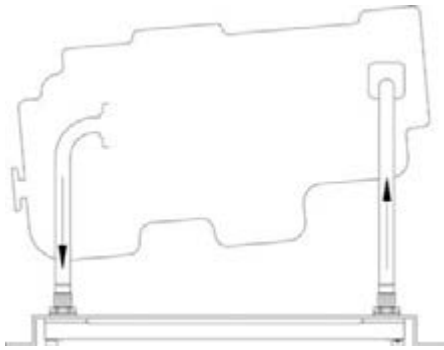

FIG. 12 Plumb keel cooler directly to the engine (simplified)

- 2.5.3 As a rule-of-thumb, the expansion tank for your cooling system should be able to hold approximately 10% of the total cooling system coolant. Contact your engine dealer for the exact size.
- 2.5.4 When piping, do not use tubing or fittings smaller than the engine or keel cooler connections. If those on the engine are larger than those on the keel cooler, reduce the piping at the keel cooler, not the engine. Use a minimum of elbows, and check all connections for leaks. All high areas in piping must be vented.
- 2.5.5 To avoid transmitting engine vibrations to the GRIDCOOLER unit, use wire reinforced rubber hoses and clamps at the engine and keel cooler connections.
- 2.5.6 When installing a multiple-pass unit in a side mounted position, the inlet line should be connected to the lower nozzle to force air up and out of the cooling system. Special units can be ordered with additional air bleeding vents in the stud end of the cooler.
- 2.5.7 To avoid air pockets that would restrict water flow through the cooling system and cause overheating, install the piping between the engine and the cooler so that it is self-venting.

NOTE: Depending on installation, special air bleeding vents are available as an option.

- 2.5.8 For piping diagrams for multiple cooler installations, see Figures 13 through 16.



FIG. 13 Coolers connected in parallel

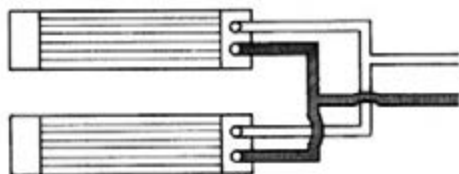

FIG. 14 Multiple-pass coolers connected in parallel

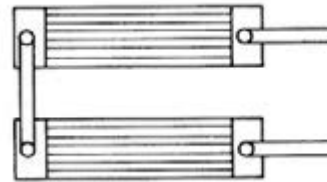

FIG. 15 Coolers connected in series

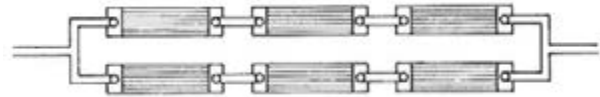

FIG. 16 Coolers connected in series parallel

2.6 FILLING & TESTING

NOTE: Do not exceed 35 PSI (2.41 Bar) when pressure testing a GRIDCOOLER® Keel Cooler.

- 2.6.1 Always premix ethylene glycol (antifreeze) with water before adding it to the cooling system. Contact your engine dealer for the proper antifreeze type and percentage for your engine. We do not recommend the use of propylene glycol in your cooling system.
- 2.6.2 Never mix ethylene and propylene glycol based antifreezes in your cooling system.
- 2.6.3 When installing a GRIDCOOLER Keel Cooler in a side mounted position, it is important that the unit is completely filled with water before launching the vessel. This can be accomplished by using the following procedure:
 1. At the outlet end of the unit, remove the upper drain plug and fill the unit with cooling water. See Figure 17
 2. When water runs out of the upper drain, replace the plug.
 3. The unit is now filled with water. If the system is ever drained, you must repeat this procedure.

NOTE: Do not exceed 35 PSI (2.41 Bar) when pressure testing a GRIDCOOLER® Keel Cooler.



FIG. 17 Remove upper drain plug to bleed air from the system.

SPECIAL INSTALLATIONS

3.0 SPECIAL INSTALLATIONS

3.1 COFFERDAM INSTALLATION WITH COMPRESSION GASKETS(see Figure 18)

3.1.1 Place a continuous bead of sealant around the header gasket that separates the GRIDCOOLER® unit from the outer hull. Customers have reported good success with polysulfide rubber sealants such as 3M Marine Sealant 101 or BoatLIFE Caulk.

NOTE: BoatLIFE is available from Life Industries (www.boatlife.com), call 800-382-9706 for a dealer near you. Marine Sealant 101 is available from 3M (www.3m.com), call 888-364-3577 for a dealer near you.

3.1.2 Hoist the unit up into the mounting position. The exterior header gasket must be in full contact with the hull.

3.1.3 Place a second continuous bead of sealant on the inner hull around the nipple. This bead must be in contact with the hull and the nipple.

3.1.4 Place the nipple gasket (harder of the two interior gaskets) down over the nozzle as far as possible.

3.1.5 Place the unfinished cast washer down over the nipple as far as possible. The side of the washer marked "up" must face away from the hull.

3.1.6 Place the compression gasket (softer of the two interior gaskets) down over the nipple as far as possible.

3.1.7 Place the semi finished washer down over the nipple, finished side away from the hull.

3.1.8 Run the nut down over the nipple and torque to spec. (See chart in Section 2.3.2)

3.1.9 Torque the nut to spec a second time after the sealant has set.

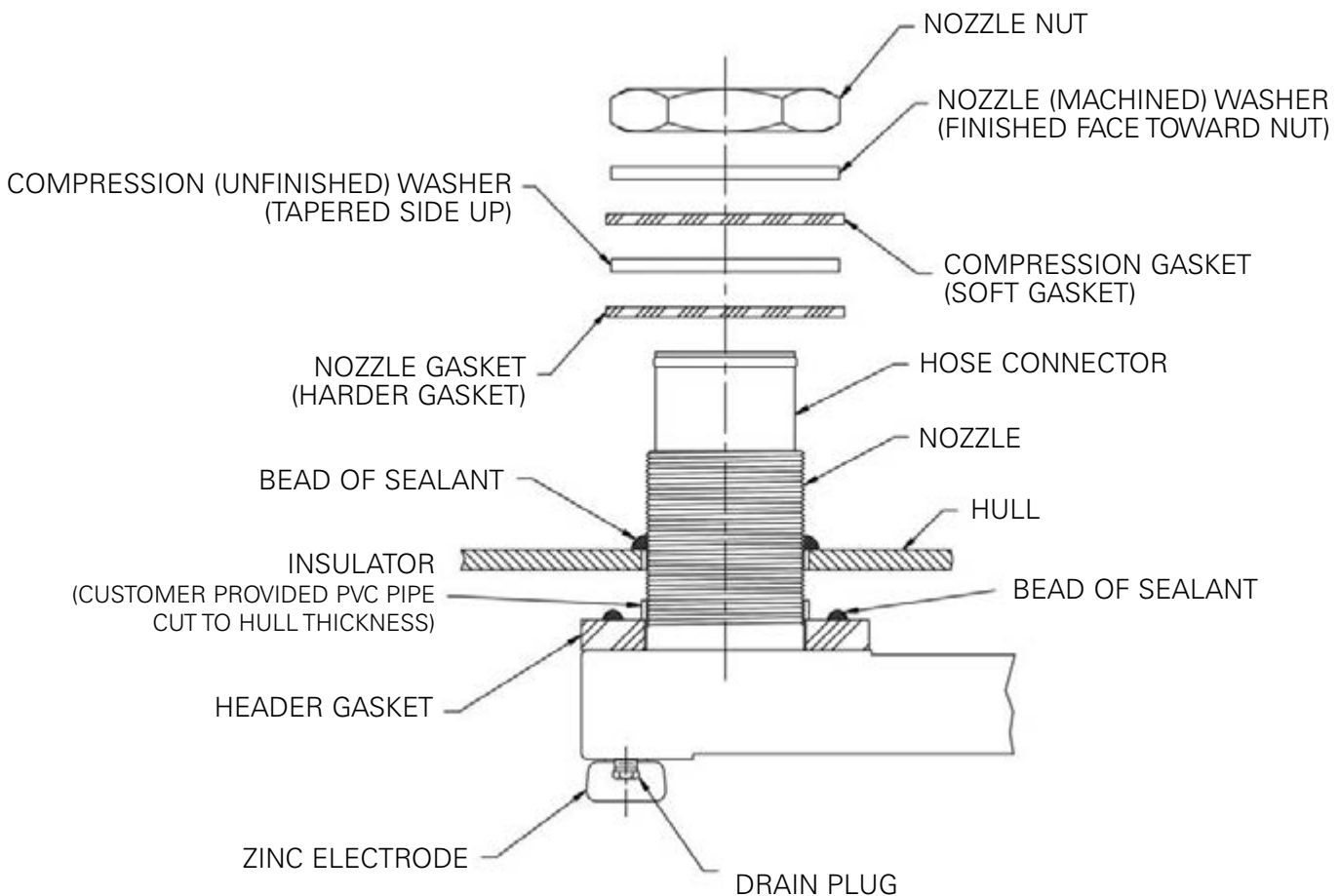

FIG. 18 Compression Sealing Parts Placement

OPTION: For ease of installation and maintenance, pipe to the side of the cofferdams. (see Figure 19)

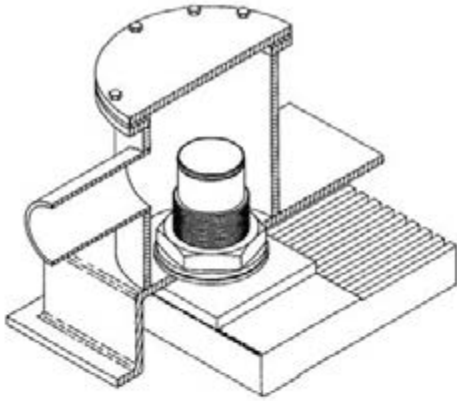

FIG. 19 Pipe to side of cofferdam

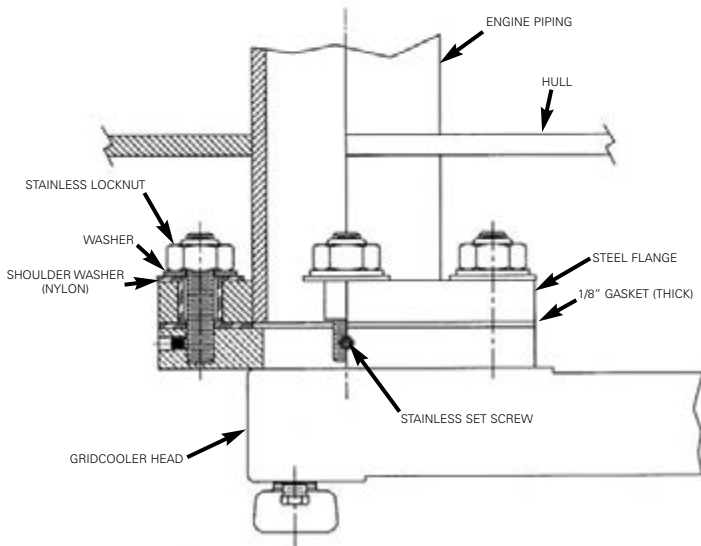

FIG. 20 Z OPTION mounting detail

3.2 Z OPTION™ INSTALLATIONS

- 3.2.1 The Z OPTION GRIDCOOLER Keel Cooler replaces the typical through-hull nozzle mounting/connecting means with a copper-nickel flange, fused to the header. This flange utilizes a plurality of stainless steel mounting studs locked in place by setscrews to allow replacement in the event of damage.
- 3.2.2 The unit is also supplied with mating ASTM steel flanges and flange mounting hardware. The supplied hardware illustrated in Figure 20 includes nylon shoulder washers combined with neoprene gaskets to allow isolation from the vessel's hull. Special extra heavy lock nuts and washers are provided for a secure installation.
- 3.2.3 Flange mounting hardware can be found in a cardboard box inside the unit shipping box.
- 3.2.4 The mating steel flange is welded to a pipe stub extending from the hull of the vessel. This pipe stub must be long enough to allow access to the flange lock nuts for tightening. Alignment of the flanges on the hull is critical. We suggest that a template be made of the cooler to aid with the proper alignment of the flanges.

NOTE: Temporarily remove nylon shoulder washers while welding. Re-insert prior to mounting cooler

- 3.2.5 The torque specification for the flange nuts is as follows:

FLANGE NUT TORQUE SPECIFICATIONS	
.625" diameter or large stud	.500" diameter stud
35-40 Ft. Lbs.	20-25 Ft. Lbs.

NOTE: Z OPTION units utilize our L OPTION™ support plates for intermediate mounting of the cooler. See the next section for L OPTION mounting instructions.

SPECIAL INSTALLATIONS

3.3 L OPTION™ SUPPORT PLATE INSTALLATION

The L OPTION support plates do not require a through-hull penetration. These support plates extend beyond the sides of the keel cooler allowing the customer the option to weld a mounting stud directly to the hull or to weld a short piece of angle to the hull as a securing means. The customer can

then install the appropriate fasteners for the support plates. Figures 21 and 22 show examples of this style of mounting. The combination of the neoprene gasket and the nylon shoulder washer provide isolation of the cooler from the hull.

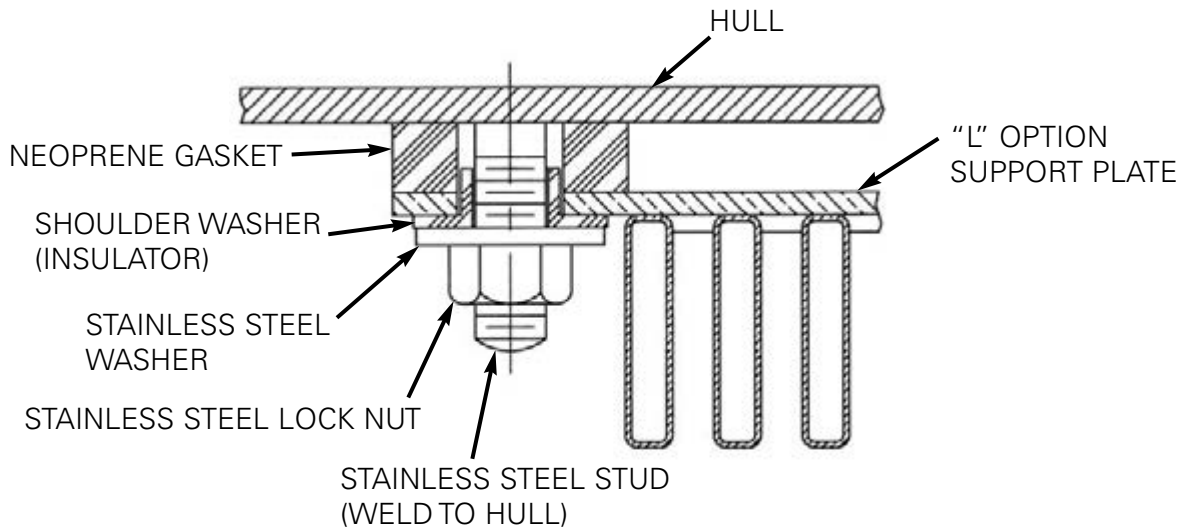

FIG. 21 L OPTION support plate with stud welded to hull

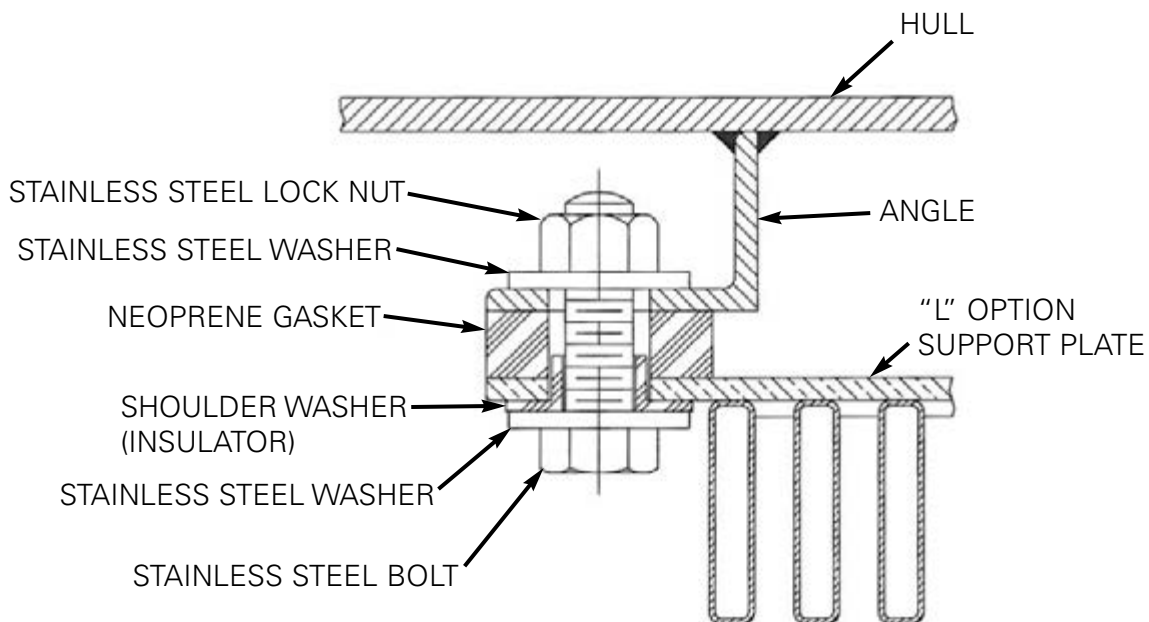

FIG. 22 L OPTION support plate with angle welded to hull

3.4 MOUNTING COPPER/NICKEL COOLERS ON ALUMINUM HULLS

An electrical barrier must be placed between the GRIDCOOLER® unit and the hull. R. W. Fernstrum & Company does not formally approve any method of installing a copper/nickel GRIDCOOLER Keel Cooler on aluminum hulled vessels. However, the following technique has been used on hundreds of boats.

- 3.4.1 Sandblast the area of the hull where the unit will be installed.
- 3.4.2 Coat the sandblasted area with a two-part fiberglass epoxy resin.
- 3.4.3 Spray the resin on in four separate coats. Don't use any matting. Spray each coat just heavy enough so that it doesn't start to run off.
- 3.4.4 After spraying on the fourth coat, and while the resin is still tacky, prime the entire area with the hull priming paint used on the rest of the vessel's hull.
- 3.4.5 Apply the final bottom paint, and then install the cooler.

FORMING GRIDCOOLER KEEL COOLER

4.0 FORMING THE GRIDCOOLER® KEEL COOLER

4.1 BENDING A GRIDCOOLER KEEL COOLER

When bending a cooler in a press, support the cooler from underneath with wood blocking across the entire width of the unit. Blocking is also placed on top of the cooler, centrally located between the wood blocking underneath the cooler. The location of the wood blocking on the top of the cooler will determine the location of the bend. Since this method of bending exerts pressure on only a small area, the cooler will need to be repositioned multiple times to produce an even bend over the length of the cooler. Care must be taken to ensure that the unit is not bent too far at any one point. A tape measure or other measuring instrument, along with a template of the hull profile can be used to measure your progress. See Figures 23 and 24.

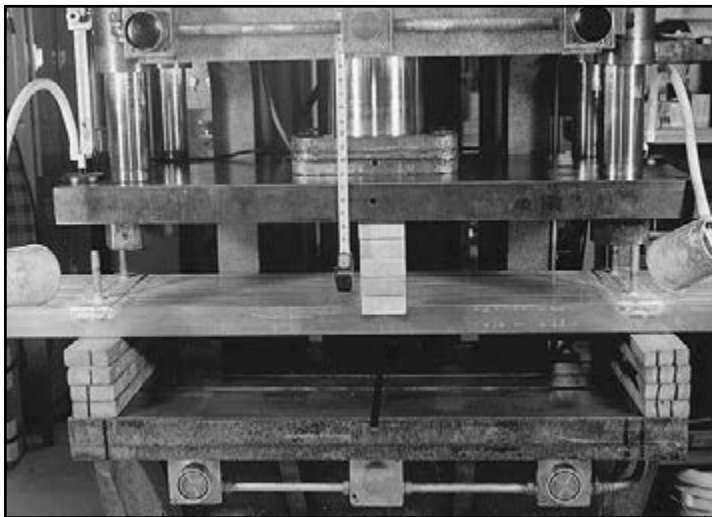

FIG. 23 *Creating a bend in a cooler using a hydraulic press*

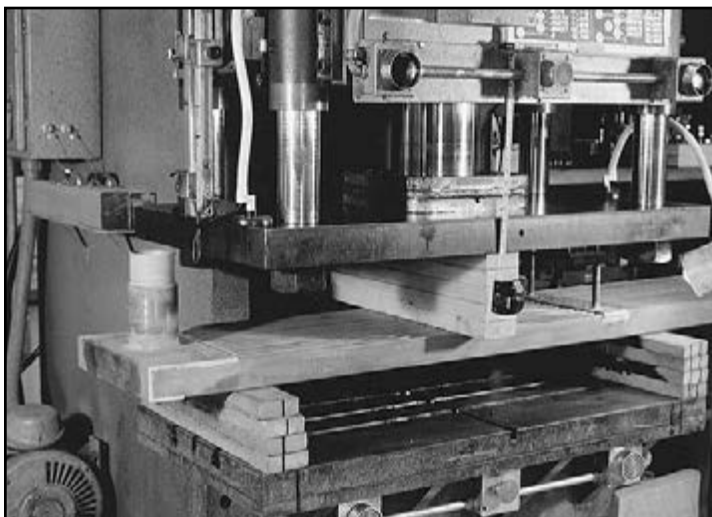

FIG. 24 *Creating a bend in a cooler using a hydraulic press*

4.2 TWISTING A GRIDCOOLER KEEL COOLER

To produce a twist, first fabricate a hook onto the end of a short length of pipe using barstock. Hook this bar across the header as close to the nipple or stud as possible. The cooler may be secured in a press or placed on sawhorses with a person at each end. By placing your weight on the end of the pipe, you can produce a twist in the cooler. See Figures 25 and 26.

**NOTE: Do Not Bend greater than 1" over 12" of cooler length.
Do Not Twist beyond 1° over 12" of cooler length.**



FIG. 25 *Locate twisting hook as close as possible to the nozzle or stud*



FIG. 26 *Carefully apply downward force to impart a twist in the cooler*

5.0 PERFORMANCE ISSUES

Determining the cause of overheating can be difficult. Here are some things to look for:

5.1 Wire Reinforced Rubber Hose:

Could the rubber hose part of the piping between the engine and the cooler be collapsed? This could cut the cooling water supply to the unit and reduce its efficiency. Be sure you are using wire reinforced rubber hose.

5.2 Piping:

Is the piping between the engine and the cooler as large or larger than the engine and cooler connections? (See section 2.5.4 under plumbing.) The piping should also be self-venting and arranged so that a minimum number of elbows are used.

5.3 Jacketwater:

Is the jacketwater circulating through the cooler? It may be taking a path of least resistance through the bypass (if one exists).

5.4 Thermostat:

Could the thermostat be stuck or could the wrong thermostat be in use? If so, it could give you a faulty temperature.

5.5 Jacketwater Pump:

Is the jacketwater pump working properly? If not, it could reduce the cooling systems efficiency.

5.6 Air in the System:

Was the unit installed in a way to allow all the air in the system to escape? When a multiple-pass unit is mounted on the rake of the vessel, make sure that the nozzles are mounted in the up or high position. See sections 1.6.3, 2.5.6, 2.5.7, & 2.6.3 under Installation. See Figure 9.

5.7 Foreign Matter:

Could anything have gotten into the cooler nozzles? Make sure that the orange plastic cap plugs covering the ends of the hose connectors were removed and that no foreign matter, such as a rag, was dropped into the cooler nozzles.

5.8 Expansion Tank:

Could the water level be too low in the expansion tank? This can reduce the cooling system's efficiency.

5.9 External Coating:

Is the cooler painted or covered with any other coating? This will have an insulating effect and will greatly reduce the heat transfer rate of the unit. The standard recommendation is to not coat the keel cooler.

5.10 Water Aeration:

Could the water around the cooler be aerated in any way? Aeration will reduce the heat transfer rate of the keel cooler.

5.11 Moored at Dock:

Is the engine temperature rising while the vessel is moored in dock? If the unit is installed near the propeller, engage the propeller to circulate water past the unit, after taking the proper safety precautions.

5.12 Placement:

Is an aftercooler circuit overheating? Make sure that the low temperature cooling circuit is mounted forward of or closer to the skeg or keel than the jacketwater coolers.

5.13 Mounting Gaskets:

Were the mounting gaskets put in place when the unit was installed? The mounting gaskets supplied with the cooler must be used to provide adequate spacing between the unit and the ship's hull. This will allow water to flow freely over the cooler tubes.

5.14 Glycol:

How much glycol (antifreeze) is in the system? Perhaps the cooler was not sized for the use of glycol in the system.

NOTE: Always premix glycol with water before adding it to the cooling system.

NOTE: Never mix ethylene and propylene glycol.

5.15 Crushed Tubes:

Have the rectangular tubes on the cooler been crushed or pinched? This could restrict the internal water flow.

5.16 Blown Tubes:

Could the rectangular tubes on the unit have been blown or bulged by unusually high pressures? If so, the exterior water flow past the unit tubes could be impaired, retarding heat transfer.

5.17 Marine Growth:

Has your vessel been in dock for several months? You may find marine growth on the unit which will hinder the unit's heat transfer rate. See Maintenance Section.

5.18 Oil Deposits:

Have you had engine problems? Oil may have gotten into the cooling water system and collected in the cooler, coating it with an oil film. See Maintenance Section.

5.19 Mineral Deposits:

Could you be using hard water in the system? Mineral Deposits can collect on the tube in the cooler, lining the inside with lime, calcium, etc. See Maintenance Section.

6.0 MAINTENANCE

A GRIDCOOLER® Keel Cooler that is clean inside and out will dissipate heat most efficiently. To keep your unit clean, a periodic check of the cooling system is recommended. What follows are some ways to clean your GRIDCOOLER unit.

6.1 EXTERIOR

If the GRIDCOOLER Keel Cooler is used regularly, the 90/10 copper/nickel alloy in conjunction with the unit's operating temperature will tend to keep the exterior of the unit relatively free of marine growth. However, if the unit is not in operation for extended periods of time, marine growth may result. Below are some ways of removing marine growth, paint, etc. from the exterior of the GRIDCOOLER unit:

6.1.1 Scrape:

Scraping is an effective way of removing larger matter from a cooler. The use of a rectangular instrument works best.

6.1.2 High Pressure Water Blast:

This cleaning method is effective in cleaning many things off of a cooler (paint is a notable exception).

6.1.3 Sandblast:

Sandblasting is also very effective, but very fine sand such as 40 to 60 grit blasting media at a maximum blast pressure of 90 psi (6.21 BAR) should be used.

6.1.4 Painting:

Coolers do not require painting. Doing so will decrease the units efficiency.

6.1.5 Zinc Electrodes:

Zinc electrodes are standard equipment with most copper/nickel units. They minimize the effects of galvanic corrosion, and should be replaced when deteriorated. The life of these electrodes varies with localities.

Zinc replacement kits, including zinc electrodes, screws, and washers, can be ordered from the factory. Just give us the model number of your GRIDCOOLER Keel Cooler.

NOTE: Zinc electrodes installed on coolers provide immediate protection to the cooler only. When using protective systems, the cooler should be taken into consideration during the hull survey.

NOTE: Zinc electrodes installed on coolers provide immediate protection to the cooler only. When using protective systems, the cooler should be taken into consideration during the hull survey.

NOTE: Never sandblast an ALUMINUM GRIDCOOLER unit.

6.2 INTERIOR

The interior of your GRIDCOOLER unit may need periodic cleaning to remove oil, old glycol, mineral deposits, etc. The easiest and most convenient way of doing this is the use of a radiator flush. Contact your engine dealer for the proper radiator flush type for your engine.

6.3 PRESSURE TESTING

Do not exceed 35 PSI (2.41 Bar) when pressure testing a GRIDCOOLER® Keel Cooler.

7.0 REPAIR

For a unit in warranty, attempt no repairs without first contacting the manufacturer, otherwise your warranty will be void.

For a unit out of warranty, if the unit is accidentally damaged while in use, you can make minor shipyard repairs as follows:

7.1 STRAIGHTENING

If the tubes are accidentally bent, they can be straightened with a hard wood block and a mallet. See Figure 27.



FIG. 27 Straightening tubes with a wooden block & mallet

7.2 COPPER/NICKEL GRIDCOOLER® KEEL COOLER REPAIRS

7.2.1 Brazing:

Drain the cooler before brazing. Clean the area or joint to be brazed thoroughly with a good degreasing solvent followed by wire brushing. The braze wire should be 56% silver. Use 3/32 in. (2.24 mm) diameter braze 560 wire, with low temperature brazing flux. See Figure 28.



FIG. 28 Brazing repair

7.3 ALUMINUM GRIDCOOLER KEEL COOLER REPAIRS

7.3.1 Tig Weld:

Drain the cooler before welding. Clean the area or joint to be welded thoroughly with a good degreasing solvent followed by stainless steel wire brushing. The aluminum filler rod used in the GRIDCOOLER Keel Cooler is R 5554 series aluminum, 3/32 in. (2.24 mm) diameter wire.

7.4 TEMPORARY REPAIR

For temporary repairs, liberally apply an epoxy compound similar to Devcon UW (Part Number: 11800) under water and Interguard 822 for above water repairs.

Before applying the epoxy compound, clean the surface of the GRIDCOOLER unit and relieve any internal pressure.

NOTE: Devcon UW is available from the Devcon Corporation (www.devcon.com), call (978) 777-1100 for a dealer near you. Interguard 822 is available from the International Paint Company (www.international-marine.com), call (800) 525-6824 for a dealer near you.

For major repairs not covered by our Limited Warranty, contact us by Phone (906) 863-5553 or Fax (906) 863-5203. Give us a complete description of the damage, and we'll tell you if and how your unit can be repaired.

7.5 COUPLINGS REPAIRS

A damaged section of tube can be replaced with two couplings and a replacement length of tube.

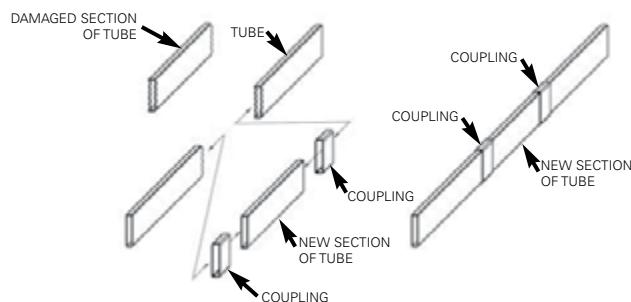

FIG. 29 Replacing a section of tube

A single coupling can be split on one narrow end, slid over the tube, and brazed into place to patch a hole in a tube.

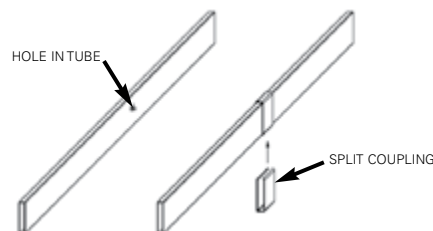

FIG. 30 Patching a hole in a tube

8.0 STRAY-CURRENT CORROSION

Since Fernstrum's involvement in the design of any particular marine vessel is limited to the heat transfer requirements of the vessel, grounding or bonding of the keel cooler is best left to the person responsible for the design of the corrosion protection system. If the customer needs guidance on this issue it's suggested to isolate the cooler from the hull and monitor closely the condition of the cooler, zincs and surrounding hull area for the first few months. This is for the simple fact that it is easier to ground a cooler after installation than it is to isolate it.

If an impressed current system is used, it is best to consult the manufacturer of the system for their recommendations as to grounding and bonding of equipment mounted to the hull.

Most corrosion experts feel that isolating the keel cooler from the steel hull is the best practice (with cathodic protection in particular). As for bonding the unit, there is sometimes a difference of opinion. In an ideal situation (i.e. no sources of stray current, no defects in the electrical system either onboard or at dockside), experts will typically recommend bonding the unit. However, in an imperfect world it's found that in some cases the opposite is the best.

Ultimately the best plan of action is to have a corrosion engineer evaluate the corrosion protection scheme of the vessel and verify its proper function.

As for the issue of the product warranty, it is not affected by how the keel cooler is configured into the corrosion protection system, as it covers defects in material and workmanship, not failure due to galvanic or stray current corrosion.

9.0 REPLACEMENT PARTS

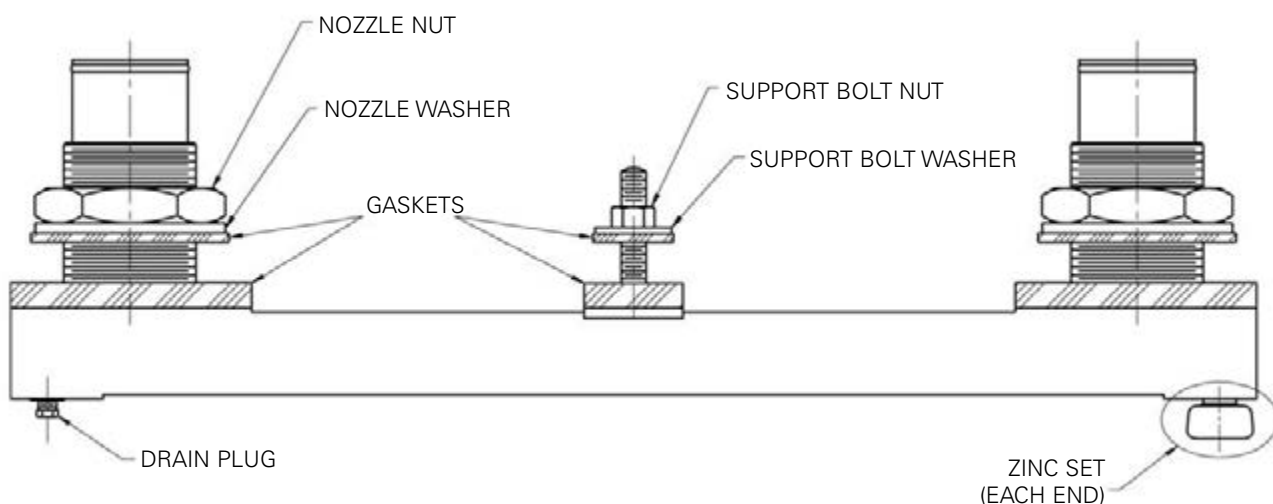

FIG. 31 Single Pass Gridcooler Keel Cooler

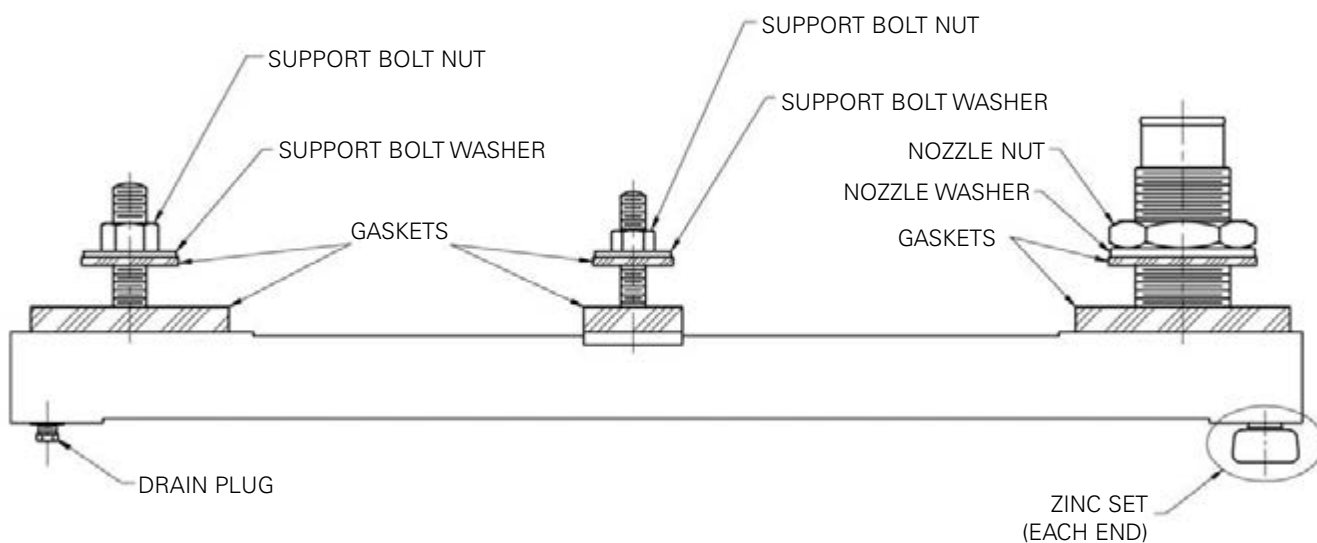

FIG. 32 Multi Pass Gridcooler Keel Cooler

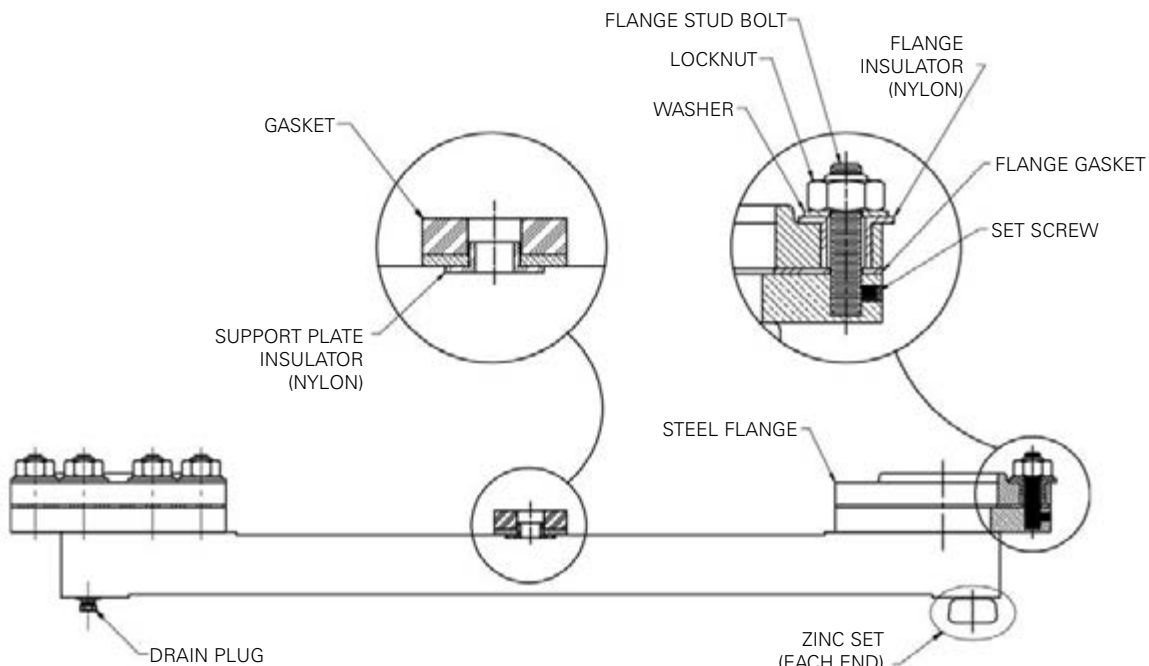

FIG. 33 Z-Option Single Pass Gridcooler Keel Cooler

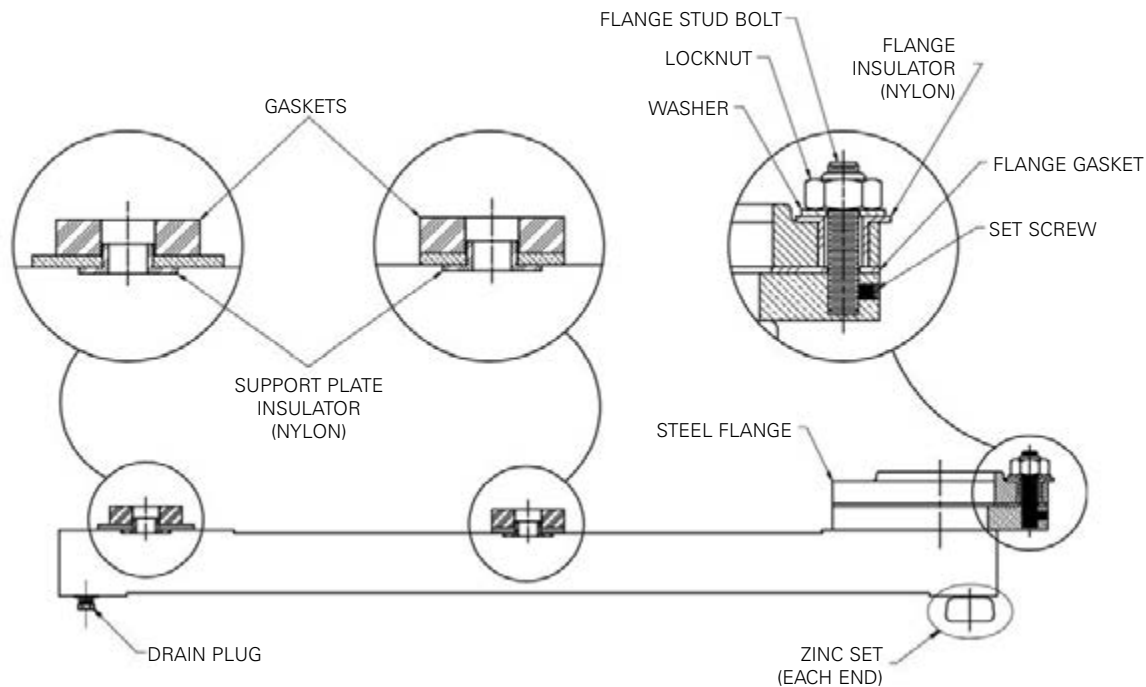

FIG. 34 Z-OPTION MULTI PASS GRIDCOOLER KEEL COOLER

NOTE: All gaskets are sold in a complete set. Sets include all internal gaskets, exterior gaskets and isolators.

NOTE: Zincs are sold in sets consisting of two (2) zinc anodes, four (4) mounting bolts and four (4) washers. One (1) Keel Cooler requires one (1) set. Keel Cooler model number is needed to identify correct set.

NOTE: Visit website for standard Keel Cooler replacement parts listed. www.fernstrum.com
For specials call factory direct.

10.0 Limited Warranty

THIS LIMITED WARRANTY GIVES YOU SPECIFIC LEGAL RIGHTS AND YOU MAY ALSO HAVE OTHER RIGHTS, WHICH VARY FROM STATE TO STATE.

THE LIMITED WARRANTY CAN ALSO BE FOUND ONLINE AT <http://www.fernstrum.com/support/grid-cooler-keel-cooler/> AND IN THE DOCUMENTATION WE PROVIDE WITH THE PRODUCT.

WE WARRANT THAT DURING THE WARRANTY PERIOD, THE PRODUCT WILL BE FREE FROM DEFECTS IN MATERIALS AND WORKMANSHIP.

TO THE EXTENT NOT PROHIBITED BY LAW, THIS WARRANTY IS EXCLUSIVE AND IN LIEU OF ALL OTHER WARRANTIES, ORAL, WRITTEN, STATUTORY, EXPRESS OR IMPLIED. EXCEPT FOR THE EXPRESS WARRANTIES CONTAINED IN THIS LIMITED WARRANTY STATEMENT AND TO THE EXTENT NOT PROHIBITED BY LAW, WE DISCLAIM ALL OTHER WARRANTIES, EXPRESSED OR IMPLIED, STATUTORY OR OTHERWISE, INCLUDING WITHOUT LIMITATION, THE WARRANTIES OF MERCHANTABILITY AND FITNESS FOR A PARTICULAR PURPOSE. SOME STATES DO NOT ALLOW DISCLAIMERS OF IMPLIED WARRANTIES, SO THIS DISCLAIMER MAY NOT APPLY TO YOU. TO THE EXTENT SUCH WARRANTIES CANNOT BE DISCLAIMED UNDER THE LAWS OF YOUR JURISDICTION, WE LIMIT THE DURATION AND REMEDIES OF SUCH WARRANTIES TO THE DURATION OF THIS EXPRESS LIMITED WARRANTY. SOME STATES DO NOT ALLOW LIMITATIONS ON HOW LONG AN IMPLIED WARRANTY LASTS, SO THE ABOVE LIMITATION MAY NOT APPLY TO YOU.

OUR RESPONSIBILITY FOR DEFECTIVE GOODS IS LIMITED TO REPAIR OR REPLACEMENT AS DESCRIBED BELOW IN THIS WARRANTY STATEMENT.

1. WHO MAY USE THIS WARRANTY?

R.W. Fernstrum & Company, located at 1716 11th Ave. Menominee, Michigan 49858 USA (“we”) extend this limited warranty only to the original purchaser of the product (“you”). This limited warranty does not extend to any subsequent owner or other transferee of the product.

2. WHAT DOES THIS WARRANTY COVER?

This limited warranty covers defects in materials and workmanship of the GRIDCOOLER® Keel Cooler (the “product”) for the Warranty Period as defined below.

3. WHAT DOES THIS WARRANTY NOT COVER?

This limited warranty does not cover any damage due to: (a) transportation; (b) storage; (c) misuse, improper use or improper installation; (d) failure to follow the product instructions or to perform any preventive maintenance (e) modifications (f) unauthorized repair; (g) normal wear and tear; or (h) external causes such as accidents, abuse, chemical, biological or electrical corrosion or other actions or events beyond our reasonable control.

4. WHAT IS THE PERIOD OF COVERAGE?

This limited warranty starts on the date of delivery and lasts for 90 days for the aluminum GRIDCOOLER® Keel Cooler, and lasts for 2 years for the copper/nickel GRIDCOOLER® Keel Cooler (the “Warranty Period”). The Warranty Period is not extended if we repair or replace the product. We may change the availability of this limited warranty at our discretion, but any changes will not be retroactive.

5. WHAT ARE YOUR REMEDIES UNDER THIS WARRANTY?

With respect to any defective product during the Warranty Period, we will, in our sole discretion repair or replace such product (or the defective part) free of charge. The cost of repair or replacement does not include labor, transportation, freight, haul-out, launch, towing, dry docking, storage charges, mechanic travel time, inconvenience, loss of time or income, removal and replacement and/or modifications of any boat parts to facilitate repair or replacement.

6. HOW DO YOU OBTAIN WARRANTY SERVICE?

To obtain warranty service, you must call (906) 863-5553 during the Warranty Period to obtain a Return Merchandise Authorization (“RMA”) number. No warranty service will be provided without an RMA number. The product or part must be returned with the RMA number noted. You are responsible for the cost of shipping the returned product or part. Upon calling the above number, customer service will walk you through the steps to request warranty service.

CONTINUED ON THE NEXT PAGE

LIMITED WARRANTY

7. LIMITATION OF LIABILITY

THE REMEDIES DESCRIBED ABOVE ARE YOUR SOLE AND EXCLUSIVE REMEDIES AND OUR ENTIRE LIABILITY FOR ANY BREACH OF THIS LIMITED WARRANTY. OUR LIABILITY SHALL UNDER NO CIRCUMSTANCES EXCEED THE ACTUAL AMOUNT PAID BY YOU FOR THE DEFECTIVE PRODUCT, NOR SHALL WE UNDER ANY CIRCUMSTANCES BE LIABLE FOR ANY CONSEQUENTIAL, INCIDENTAL, SPECIAL OR PUNITIVE DAMAGES OR LOSSES, WHETHER DIRECT OR INDIRECT.

SOME STATES DO NOT ALLOW THE EXCLUSION OR LIMITATION OF INCIDENTAL OR CONSEQUENTIAL DAMAGES, SO THE ABOVE LIMITATION OR EXCLUSION MAY NOT APPLY TO YOU.

8. WHAT CAN YOU DO IN CASE OF A DISPUTE WITH US?

The following informal dispute resolution procedure is available to you if you believe that we have not performed our obligations under this limited warranty: should a dispute arise, you should contact customer service at (906) 863-5553. You must use this informal procedure before pursuing any legal remedy in the courts. All such disputes shall be governed by the laws of the State of Michigan to the extent that the same do not conflict with the laws of the United States.

**PLEASE KEEP THIS FORM ON THE VESSEL FITTED WITH THE GRIDCOOLER UNITS.
THE INFORMATION BELOW WILL BE OF USE FOR FUTURE REFERENCE.**

ENGINE INFORMATION			GRIDCOOLER INFORMATION	
MAKE OF ENGINE	MODEL OF ENGINE	HP/RPM (KW/RPM)	MODEL OF GRIDCOOLER	QUANTITY
_____	_____	_____	_____	_____
_____	_____	_____	_____	_____
_____	_____	_____	_____	_____
_____	_____	_____	_____	_____
_____	_____	_____	_____	_____
_____	_____	_____	_____	_____
_____	_____	_____	_____	_____
_____	_____	_____	_____	_____

RECOMMENDATION FORM

Date _____

Initials _____

ENGINE INFO

TYPE Propulsion Bow Thruster Generator Other _____

Tier _____

Make _____

Model _____

HP & RPM _____

Heat Rejection _____

Fresh Water Flow Rate _____

Fresh Water Temp into Cooler _____ Drop Out

Fresh Water Temp Out or Drop Across Cooler _____

Minimum Hull Speed at Full Rated Power under full load) (If Speed is 0 knots, or the engine is used as a generator size for 1/2 mph) _____

Maximum Sea Water Temp _____ Engine Age _____ % Antifreeze Used _____

Make & Model of Gear _____

Type of Boat (ferry, trawler, pleasure boat, etc.) _____

Hull Construction Steel Fiberglass Wood Aluminum Painted Unpainted

Comments

CUSTOMER

PHONE _____

FAX _____

E-MAIL _____

FERNSTRUM[®]

R.W. Fernstrum & Company

fernstrum.com

Phone: 906.863.5553 • Fax: 906.863.5203 • Email: sales@fernstrum.com
P.O. Box 97 • 1716 11th Avenue • Menominee, Michigan 49858 • USA

© 2016 R.W. Fernstrum & Company. All Rights Reserved.
FERNSTRUM[®] and GRIDCOOLER[®] are registered trademarks of R.W. Fernstrum & Company.